

# SATURNA

## Natural Gas & Propane Direct Vent Gas Fireplace Insert Installation and Operating Instructions



**WARNING:** If the information in this manual is not followed exactly, a fire or explosion may result causing property damage, personal injury, or loss of life.

### For your safety

Do not store or use gasoline or other flammable vapors and liquids in the vicinity of this or any other appliance.

### What to do if you smell gas

- Do not try to light any appliance.
- Do not touch any electrical switch; do not use any phone in your building.
- Immediately call your gas supplier from a neighbor's phone. Follow the gas supplier's instructions.
- If you cannot reach your gas supplier, call the fire department.

Installation and service must be performed by a qualified installer, service agency or the gas supplier.

**Please read this manual before installing or using this appliance. Retain this manual for future reference.**

# Table of Contents

<b>1.0 INTRODUCTION</b> .....	<b>3</b>
1.1 SPECIFICATIONS .....	3
1.2 FEATURES.....	5
1.3 INTENDED USE .....	5
1.4 GENERAL SAFETY .....	5
<b>2.0 OPERATION</b> .....	<b>6</b>
2.1 OPERATION SAFETY .....	6
2.2 LIGHTING INSTRUCTIONS .....	7
2.3 HEAT OUTPUT ADJUSTMENT .....	8
2.4 FAN OPERATION .....	8
<b>3.0 INSTALLATION</b> .....	<b>8</b>
3.1 INSTALLATION AND SAFETY NOTES.....	8
3.2 UNPACKING .....	8
3.3 INSTALLATION .....	9
3.3.1 MINIMUM CLEARANCES TO COMBUSTIBLES .....	9
3.3.2 GAS LINE INSTALLATION.....	11
3.3.3 THERMOSTAT OR WALL SWITCH INSTALLATION .....	11
3.3.4 VENT INSTALLATION .....	14
3.3.5 FACEPLATE INSTALLATION.....	19
3.3.6 FIRE BOX COMPONENTS INSTALLATION .....	21
3.3.6.3 DECORATIVE DOORS INSTALLATION .....	23
3.3.7 INITIAL FIRING.....	24
3.3.7.4 DAMPER ADJUSTMENT.....	27
3.3.8 BURNER REMOVAL .....	29
3.3.9 FIELD CONVERSIONS .....	30
<b>4.0 MAINTENANCE</b> .....	<b>31</b>
4.1 MAINTENANCE SAFETY .....	31
4.2 RECOMMENDED SERVICE .....	31
4.3 GLASS CLEANING.....	31
4.4 CLEANING OF GOLD PLATED SURFACES .....	32
4.5 BURNER & PILOT CLEANING.....	32
4.6 FAN REPLACEMENT & ELECTRICAL SCHEMATIC.....	32
<b>5.0 TROUBLE SHOOTING</b> .....	<b>34</b>
<b>6.0 REPLACEMENT PARTS</b> .....	<b>36</b>
<b>OSBURN LIMITED LIFETIME WARRANTY</b> .....	<b>37</b>

# **1.0 INTRODUCTION**

## **1.1 Specifications**

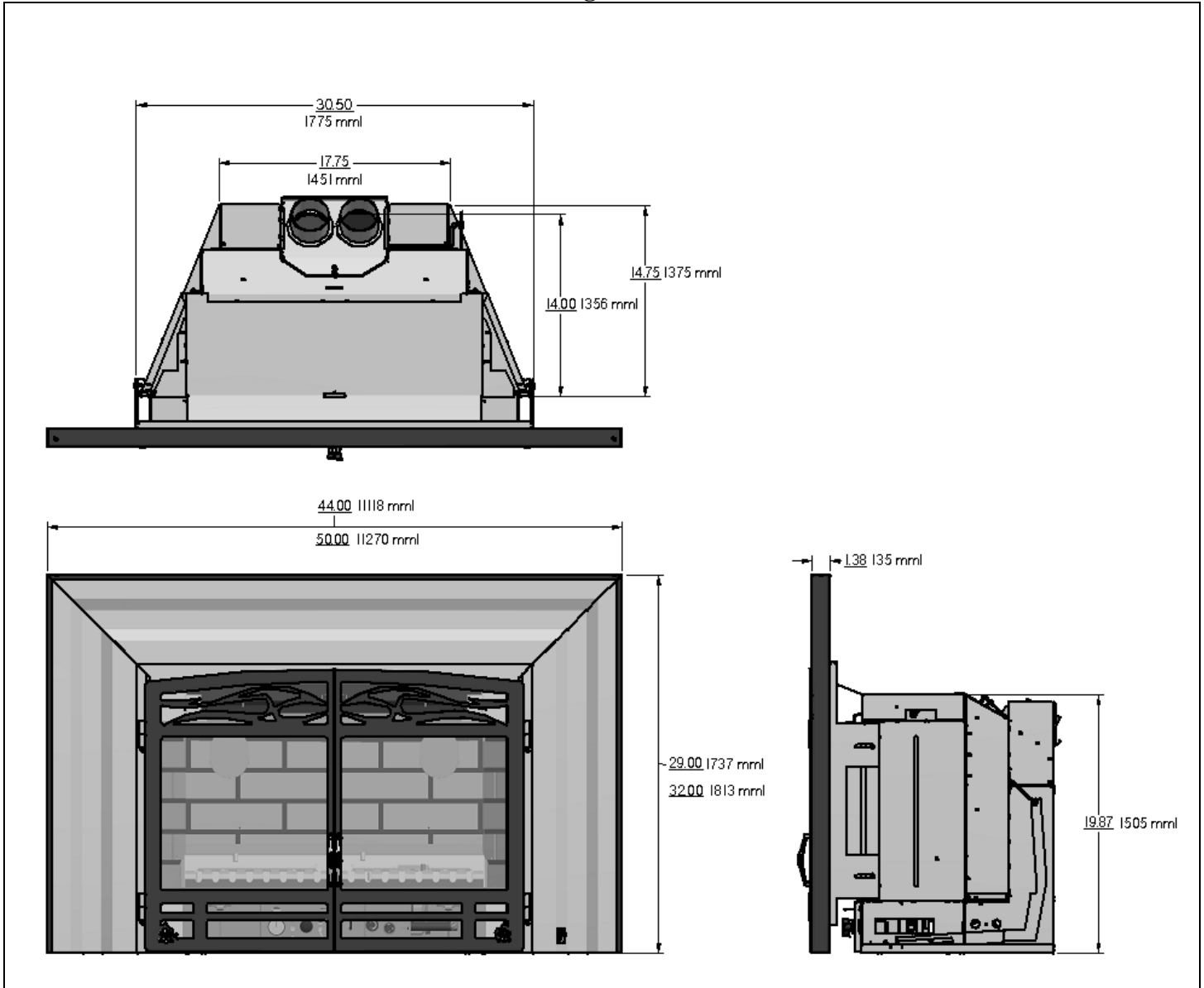
**TABLE 1**

<b>ITEM</b>	<b>NATURAL GAS (NG)</b>	<b>PROPANE (LPG)</b>
INPUT: Hi	35,000 Btu/hr (10.25kW)	35,000 Btu/hr (10.25kW)
INPUT: Lo	17,500 Btu/hr (5.13kW)	17,500 Btu/hr (5.13kW)
MANIFOLD PRESSURE: Hi	3.5" w.c. (0.82kPa)	10.0" w.c. (2.49kPa)
GAS INLET SUPPLY PRESSURE:	Minimum: 5.0" w.c. (1.2 kPa)	Minimum: 11.0" w.c. (2.7 kPa)
	Normal: 7.0" w.c. (1.7 kPa)	Normal: 13.3" w.c. (3.3 kPa)
	Maximum: 13.5" w.c. (3.4 kPa)	Maximum: 13.5" w.c. (3.4 kPa)
ORIFICE SIZE: @ 0-4500'	# 36 DMS (.120") (3.05mm)	# 50 DMS (.070") (1.78mm)
AIR SHUTTER OPENING	*CLOSED	*25% to 50% OPEN
CONTROL VALVE TYPE:	SIT 820 Nova	SIT 820 Nova
VENTING TERMINATION	Simpson « Dura-Vent », Security « Secure Vent » or Selkirk « Direct Temp »	Simpson « Dura-Vent », Security « Secure Vent » or Selkirk « Direct Temp »
FAN	Variable Speed (120 Volt)	Variable Speed (120 Volt)

**\*May vary (±25%) depending on the installations. Judgment of the installer is required.**

# APPLIANCE DIMENSIONS

Figure 1



## INSTALLATION CODES

Installation must conform to local codes. In the absence of local codes, installation must conform to the National Fuel Gas Code, ANSI Z233.1 1988, (in the U.S.), or with the current installation code CAN/CGA B149.1 – M86 (in Canada). The heater, when installed, must be electrically grounded in accordance with local codes or, in the absence of local codes, with the National Electric Code ANSI/NFPA No. 70-1990 (in the U.S.) or with the current CSA C22.1 Canadian Electrical Code (in Canada). In the state of Massachusetts, this product can only be installed by a licensed plumber or a licensed gas fitter. Failure to comply will void the warranty. In mobile homes the installation must meet the Manufactured Home Construction and Safety Standard Title 24 CFR, Part 3280, or the current Standard for Fire Safety Criteria for Manufactured Home Installations, Sites, and Communities ANSI/NFPA 501A, and with CAN/CSA Z240 MH Mobile Home Standard in Canada.

## 1.2 Features

### Ignition system:

Standing pilot ignition system with thermopile and thermocouple flame detection and piezo igniter.

### Gas control:

Automatic millivolt powered combination gas control valve with variable flame control for convenience and on/off switch, optional wall thermostat, and/or optional wireless remote control are available. The gas valve does not require electricity from an external source.

### Fan control

Variable speed control, the knob controls the fan speed in connection with a heat sensitive switch which turns on when the heater reaches operating temperature. Turning the knob counter-clockwise turns it to the "Off" position.

### Safety controls:

A safety switch (thermocouple) will shut the system down in the event of loss of pilot flame, installation is not adequate or if flue is blocked.

### Outside combustion air supply:

The combustion air supply is obtained entirely from outside the heated living space by the intake of outside air through the vent termination and down a 3" aluminum vent.

## 1.3 Intended use

This appliance is intended to be used as a direct vent (top venting) fireplace insert heater and is suitable for installation into masonry fireplaces, or into certified factory built fireplaces which include a gas line knockout and proper floor clearances. A masonry fireplace must meet the minimum building code requirements or the equivalent, for a safe installation. Factory built fireplaces and their chimneys must be certified and meet local code requirements. Both must be free from cracks, blockage, creosote deposits, loose mortar, or other types of deterioration. . In Massachusetts the Saturna may be installed in a bedroom only when used as a direct vent unit (sealed combustion). For other states or provinces it may be installed in a bedroom provided that CR89-00 and/or ANSI A225.1/NFPA 501A standards are followed, all required clearances are met, a wall thermostat is installed and where the maximum input is within 50 cubic feet of room volume per 1000 BTU/hr, (i.e.1500 minimum cubic feet) and hooked up to a Simpson GS Dura Vent , Security Chimneys International (Secure Vent) or Selkirk (Direct-Temp) vent termination.

## 1.4 General safety

The appliance **must** be properly connected to a venting system in accordance with local codes. This unit must not be connected to a chimney or flue serving any other appliance. It is equipped with a safety control system to protect against improper venting of flue products.

***WARNING: Operation of this unit when not connected to a properly installed and maintained venting system may result in carbon monoxide poisoning.***

Installation and repair should be done by a qualified service person. The appliance should be inspected before use and at least annually by a professional service technician. Provide adequate

clearances around air openings, for combustion and ventilation air, and allow accessibility clearance for servicing and proper operation.

## **2.0 OPERATION**

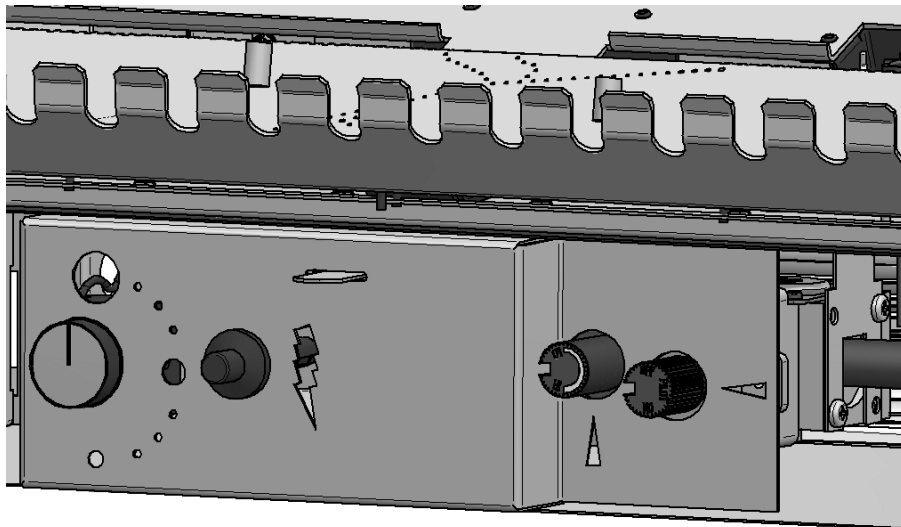
### **2.1 Operation safety**

Inspect the appliance before use. Always keep the appliance area clear and free from combustible materials, gasoline, and other flammable vapours and liquids. Never obstruct the flow of ventilation air. Keep the front of the appliance clear of all obstacles and foreign materials. Never obstruct or modify the air inlet/outlet grilles of the fireplace in any manner.

**CAUTION: Children and adults should be alerted to the hazards of high surface temperature and should stay away to avoid burns or contact with hot surfaces. Young children should be carefully supervised when they are in the same room as the heater. Clothing or other flammable material should not be placed on or near the unit.**

The glass door must be properly installed prior to operation. **Never** operate the unit with the glass door off or broken since this may cause dangerous indoor air pollution. This unit is **not** for use with solid fuel. **Do not** substitute any parts or materials. **Do not** abuse the glass door.

**Control panel knobs, from left to right :  
Fan rheostat, Piezo igniter, Hi-lo flame adjustment and On-Off-Pilot gas control.**



**Figure 2**

## 2.2 Lighting instructions

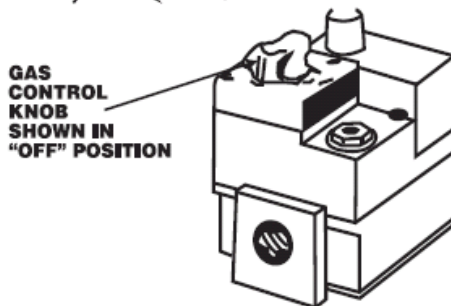
### FOR YOUR SAFETY READ BEFORE LIGHTING

**WARNING :** If you do not follow these instructions exactly, a fire or explosion may result causing property damage, personal injury or loss of life.

- A. This appliance has a pilot which must be lighted by hand. When lighting the pilot, follow these instructions exactly.
- B. **BEFORE LIGHTING** smell all around the appliance area for gas. Be sure to smell next to the floor because some gas is heavier than air and will settle on the floor.
- WHAT TO DO IF YOU SMELL GAS**
- Do not try to light any appliance.
  - Do not touch any electric switch ; do not use any phone in your building.
  - Immediately call your gas supplier from a neighbour's phone. Follow the gas supplier's instructions.
- C. Use only your hand to push in or turn the gas control knob. Never use tools. If the knob will not push in or turn by hand, don't try to repair it, call a qualified service technician. Force or attempted repair may result in a fire or explosion.
- D. Do not use this appliance if any part has been under water. Immediately call a qualified service technician to inspect the appliance and to replace any part of the control system and any gas control which has been under water.
- If you cannot reach your gas supplier, call the fire department.

### LIGHTING INSTRUCTIONS

1. STOP! Read the safety information above on this label.
2. Set the thermostat to lowest setting.
3. Turn off all electric power to the appliance.
4. Remove control access panel.
5. Push in gas control knob slightly and turn clockwise to "OFF".



**NOTE :** Knob cannot be turned from "PILOT" to "OFF" unless knob is pushed in slightly. Do not force.

6. Wait five (5) minutes to clear out any gas. Then smell for gas, including near the floor. If you smell gas, STOP! Follow "B" in the safety information above on this label. If you don't smell gas, go to the next step.

7. Remove the pilot access panel located below and behind the gas control unit.
8. Find pilot - follow metal tube from gas control. The pilot is between the two burner tubes behind the pilot access panel.
9. Turn knob on gas control counterclockwise to "PILOT".
10. Push in control knob all the way and hold in. Immediately light the pilot with piezo. Continue to hold the control knob in for about one (1) minute after the pilot is lit. Release knob and it will pop back up. Pilot should remain lit. If it goes out, repeat steps 5 through 10.
  - If knob does not pop up when released, stop and immediately call your service technician or gas supplier.
  - If the pilot will not stay lit after several tries, turn the gas control knob to "OFF" and call your service technician or gas supplier.



11. Replace pilot access panel.
12. Turn gas control knob counterclockwise to "ON".
13. Replace control access panel.
14. Turn on all electric power to the appliance.
15. Set thermostat to desired setting.

### TO TURN OFF GAS TO APPLIANCE

1. Set the thermostat to lowest setting.
2. Turn off all electric power to the appliance if service is to be performed.
3. Remove control access panel.
4. Push in gas control knob slightly and turn clockwise to "OFF". Do not force.
5. Replace control access panel.

## 2.3 Heat output adjustment

The valve supplied with the appliance has a HI/LO knob to control the heat output and flame height (Figures 2 & 3).

## 2.4 Fan operation

The fan control knob is located behind the decorative doors, below the firebox and may be adjusted to the following settings: OFF: Turn the control fully counter-clockwise until the switch operates. Variable Speed Setting: Turn the control to the desired setting. When the knob is turned fully clockwise the fan will set to minimum speed.

Do not use this appliance if any part has been under water. Immediately call a qualified service technician to inspect the appliance and to replace any part of the control system and any gas controls which have been under water.

## **3.0 INSTALLATION**

### 3.1 Installation and safety notes

Read all instructions before starting installation and follow them carefully during installation to ensure maximum benefit and safety. Failure to follow these instructions will void your warranty and may present a fire hazard. See the warranty at the back of this manual for disclaimers regarding improper installation. This fireplace insert and its components are tested and safe when installed in accordance with this installation manual.

***ELECTRICAL GROUNDING NOTE:*** A three-prong (grounding) plug, for your protection against shock hazard, is provided and should be plugged directly into a properly grounded three-prong receptacle. Do not cut or remove the grounding prong from this plug.

**WARNING: Do not connect 120 VAC to the gas control valve or it's wiring, as this will damage the valve.**

### 3.2 Unpacking

Please check the appliance carefully for any damaged or missing components (specifically check the glass condition). Report any problems to your dealer. This unit is shipped with the logs in a separate package.



### 3.3 Installation

For satisfactory results it is necessary to plan certain aspects of the installation prior to the appliance's final positioning. These include the vent system, the gas piping, and the fan wiring. Combustible surfaces such as the hearth, mantle, and facing must also be planned for.

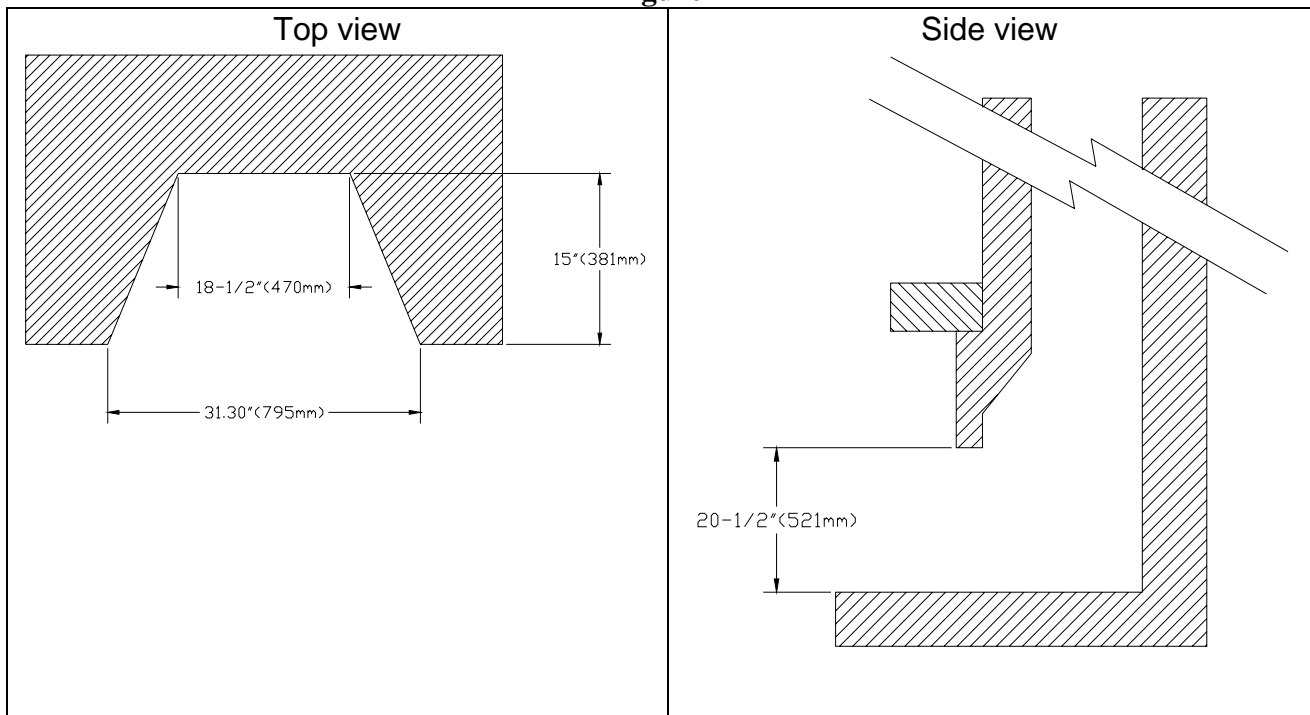
**NOTE: All Installations Require Venting.**

#### 3.3.1 Minimum clearances to combustibles

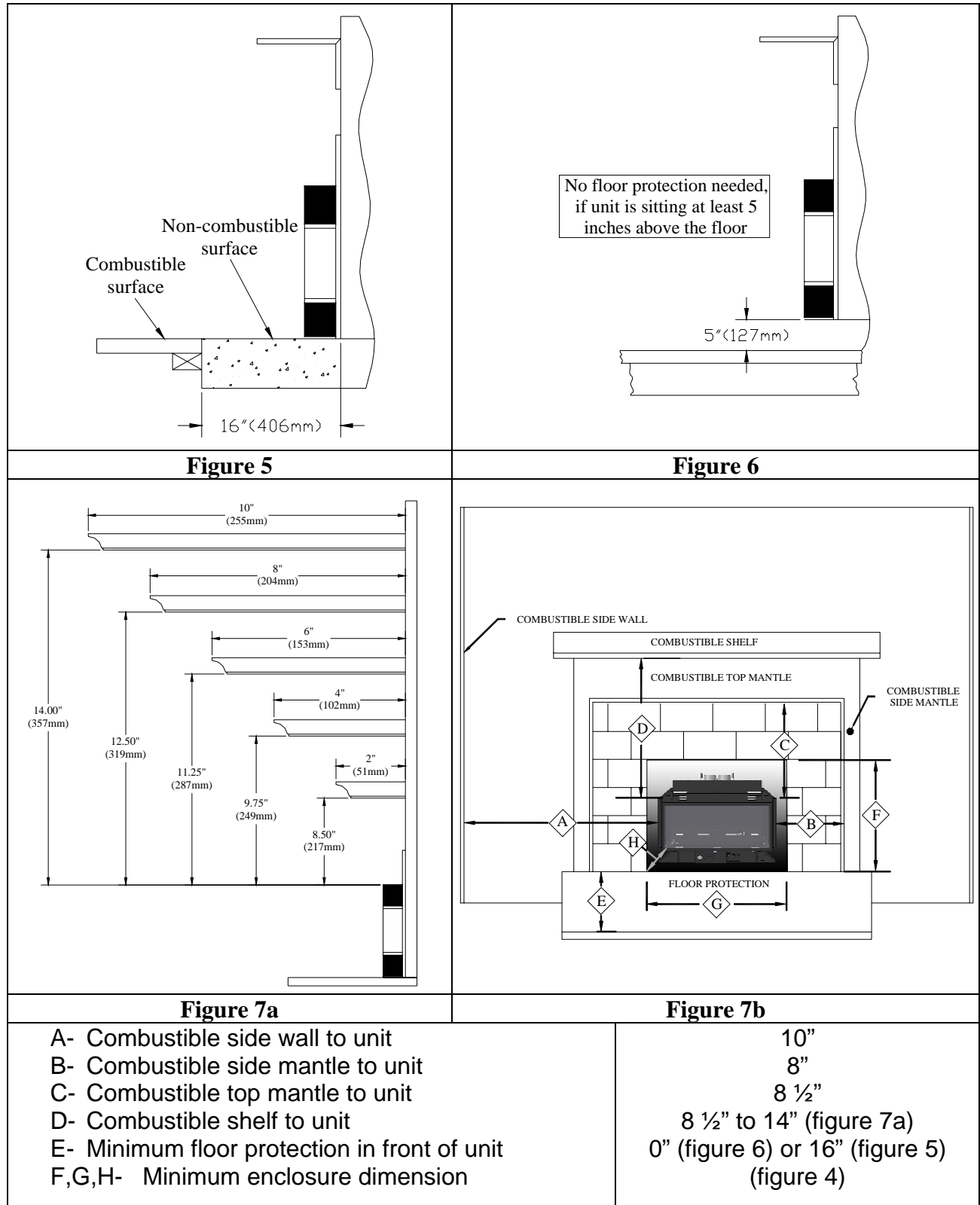
Inspect the fireplace to ensure the insert will correspond to the measurements (Figure 4).

**Minimum enclosures are as follow:**

**Figure 4**



## Minimum Clearances to Combustibles :



**Note:** When using paint or lacquer to finish the mantle, such paint or lacquer must be heat resistant to prevent discoloration.

### 3.3.2 Gas line installation

- Install supply line using any piping approved for your installation meeting CAN/CGA 6.10, AA 3, ANSI Z21.24 or Z21.45. A qualified gas fitter should install the gas line in accordance with all local building codes. If codes permit, coiled copper tubing may be used for gas supply.
- Pressure taps are provided on the gas control for test gauge connections to measure the manifold and inlet pressures.
- This appliance must be isolated from the gas supply piping system by closing its individual manual shut off valve during any pressure testing of the gas supply piping system at test pressures equal to or less than 1/2 psig (3.45 kPa).
- The appliance and its individual shut off valve must be disconnected from the gas supply piping system during any pressure testing of the system at test pressures in excess of 1/2 psig (3.45 kPa).
- Install the gas line as follows:
  - The gas line connection found on the back of the valve is a 3/8" black iron nipple. An AGA and/or CGA approved shut off valve can be installed in conjunction with the nipple if so desired. Installing the shut off valve on the end of the nipple will allow quick accessibility.
- Upon initial firing check manifold pressure at pressure tap located on the front of the control valve (Figure 3).

**WARNING: Do not use an open flame to test for gas leaks.**

### 3.3.3 Thermostat or wall switch installation

The burner control switch is located on the bottom right hand side of the faceplate (Figure 16). For your convenience, the unit can also be operated by a thermostat, or a wall switch control. Millivolt thermostats are available from any authorized Osburn dealer. Bedroom installations require the use of a wall thermostat.

**NOTE: The thermostat or wall switch MUST be rated for millivolt use. Minimize splicing in all millivolt wiring & solder all unavoidable splices.**

#### 3.3.3.1 Remote control installation

Please refer to instructions included with the optional accessory kit.

#### 3.3.3.2 Thermostat or wall switch installation

1. Mount the thermostat or wall switch in the desired location and run "two conductor thermostat wire" to the burner control switch (Figure 8a). To bypass the burner control switch, run the wires directly to the gas valve (Figure 8b).

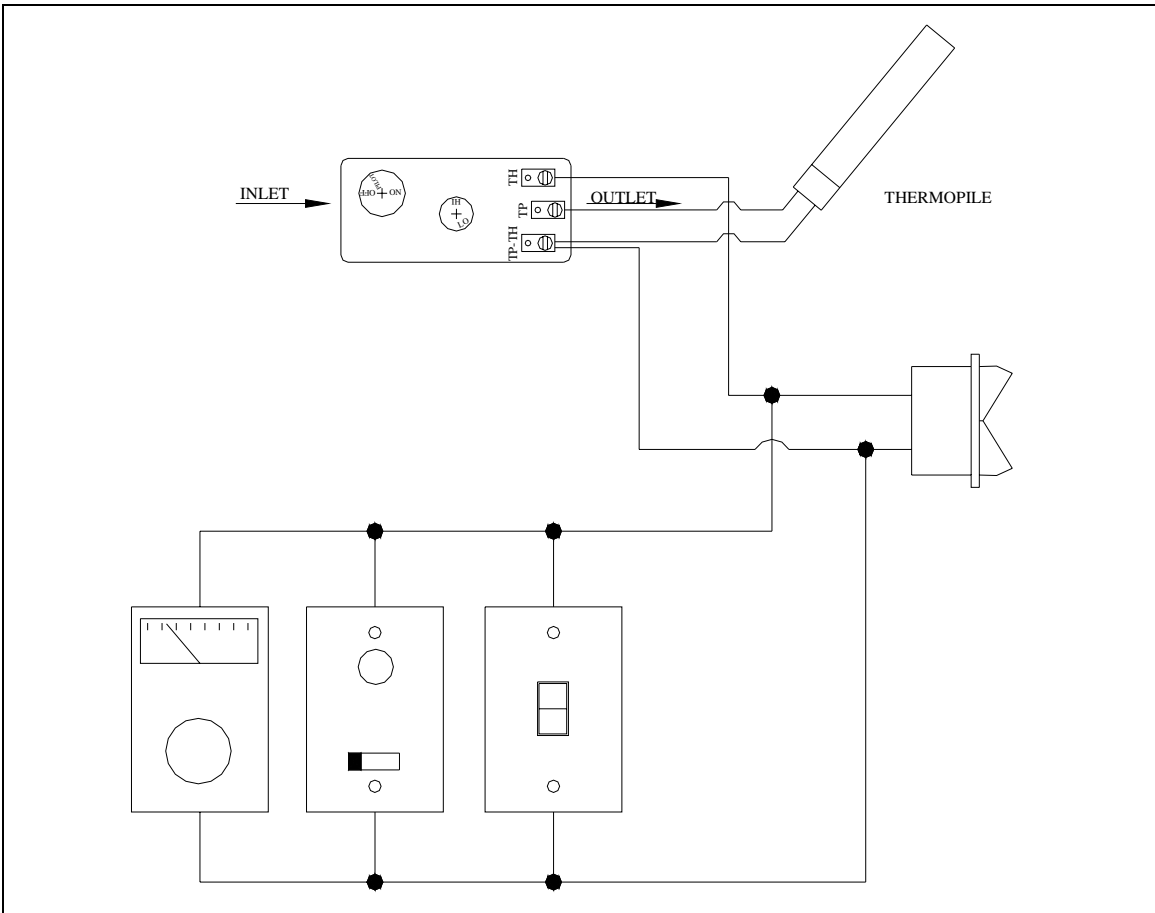
Purchase "two conductor thermostat wire", which is not provided, at any local supplier. The gauge of thermostat wire will determine the maximum wire length and distance at which to locate the thermostat or wall switch. See table 2 below and the information packaged with the thermostat. Be aware that, as the length of wire increases, the probability of adequate operating voltage decreases.

### THERMOSTAT WIRE INFORMATION

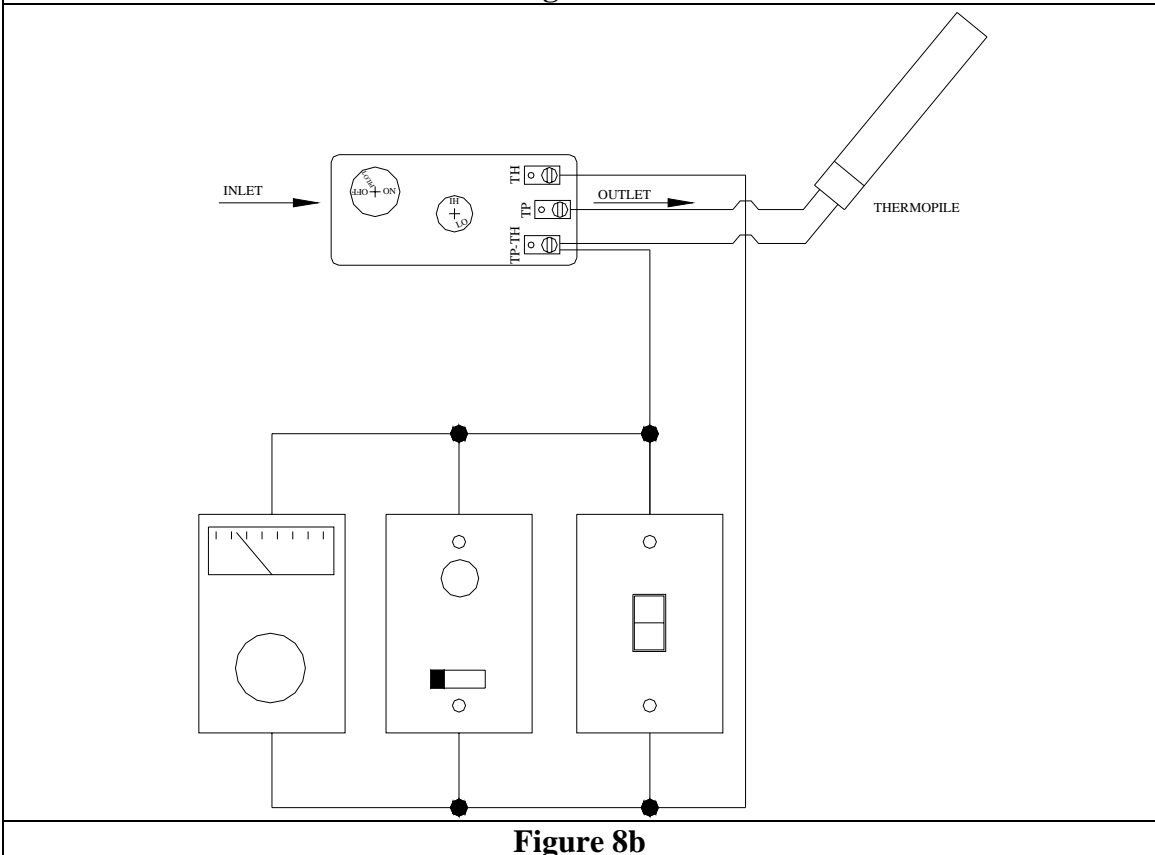
WIRE SIZE		MAX. WIRE LENGTH	
AWG	mm	ft.	m
22	0.6	10	3.1
20	0.8	25	7.6
18	1.0	40	12.2
16	1.3	64	19.5
14	1.6	100	30.5

**TABLE 2**

2. Solder an appropriate wire connector to each wire. To connect to the burner switch, 1/4" female quick connects are required and to connect directly to the valve use spade tongue connectors.
3. Check tests can be performed on the valve by referring to the trouble shooting guide.



**Figure 8a**



**Figure 8b**

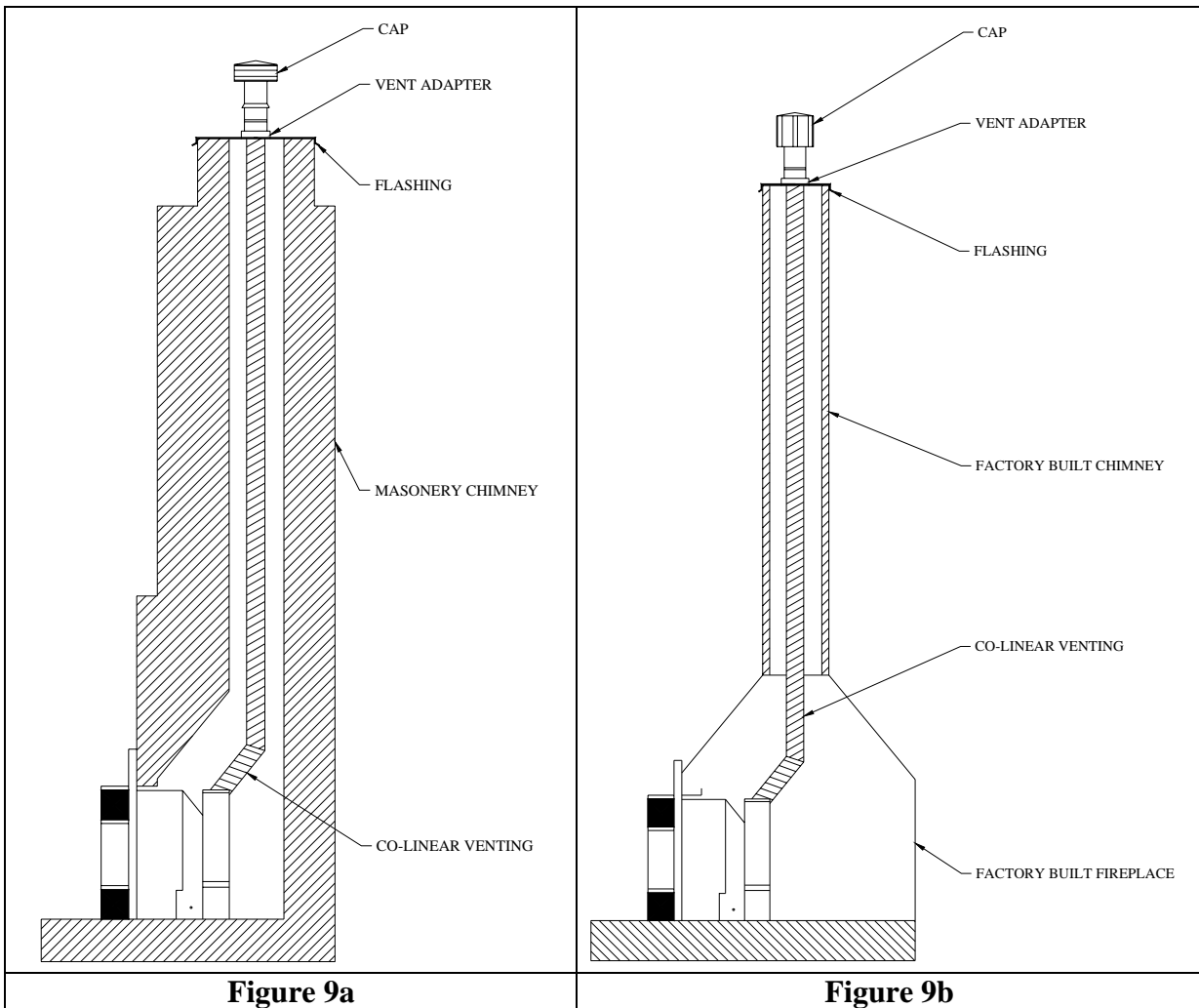
### 3.3.4 Vent installation

#### 3.3.4.1 Chimney Liner Installation

The insert must be connected to a pair of three-inch diameter listed liners suitable for use with gas. The liners must run within the existing chimney from the vent collars on the insert, to the top of the masonry or factory built chimney (Figures 9a, 9b and 10).

When installing this appliance into large fireplace cavities, the vents may be connected directly to their attachments with the appliance in place. Smaller cavities may require detaching the flue collar plate so that it can be installed separately prior to the main assembly.

Figures 9a & 9b below show the completed installations in both a masonry and a factory built fireplace.



### **Installation steps are as follows:**

1. Position the insert in the fireplace cavity and note the required positions of the vent and gas line.
2. To prevent damage to the insert, remove it until after the gas and vent lines have been positioned.
- 3
  - a. Measure and cut two liner lengths just slightly longer than required.  
Reminder: Minimum overall vent height is 11' and maximum is 30'.  
Joining two lengths of liner can be accomplished using 3" DF Flex Couplings. Join the lengths by liberally applying High Temperature Sealant to the end of the liner before inserting it onto the coupling, and once inserted, secure each connection with three screws.

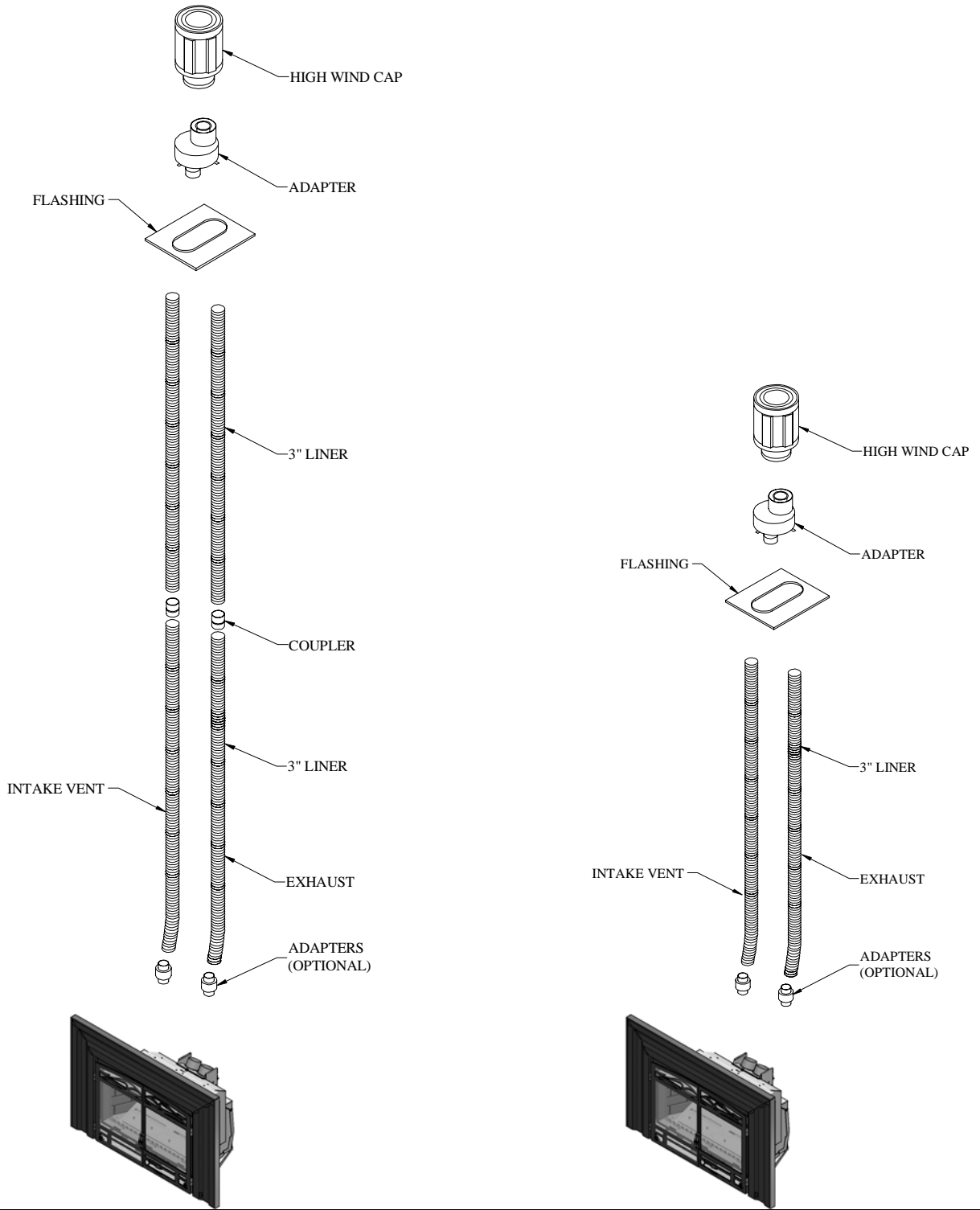
### **From the top of the chimney:**

- b. Install the flashing onto the existing chimney.
- c. Attach the liners to the two 3" outlets on the approved Chimney Liner Termination Kit by first liberally applying High Temperature Sealant to the gasketed joint, and then pushing the liner onto the collar. Secure each joint using three screws.
- d. **CLEARLY IDENTIFY** the lower end of the liners for intake and exhaust.
- e. Feed the liners down the chimney through the flashing.
- f. Install the cap onto the Round Adapter.

### **From below:**

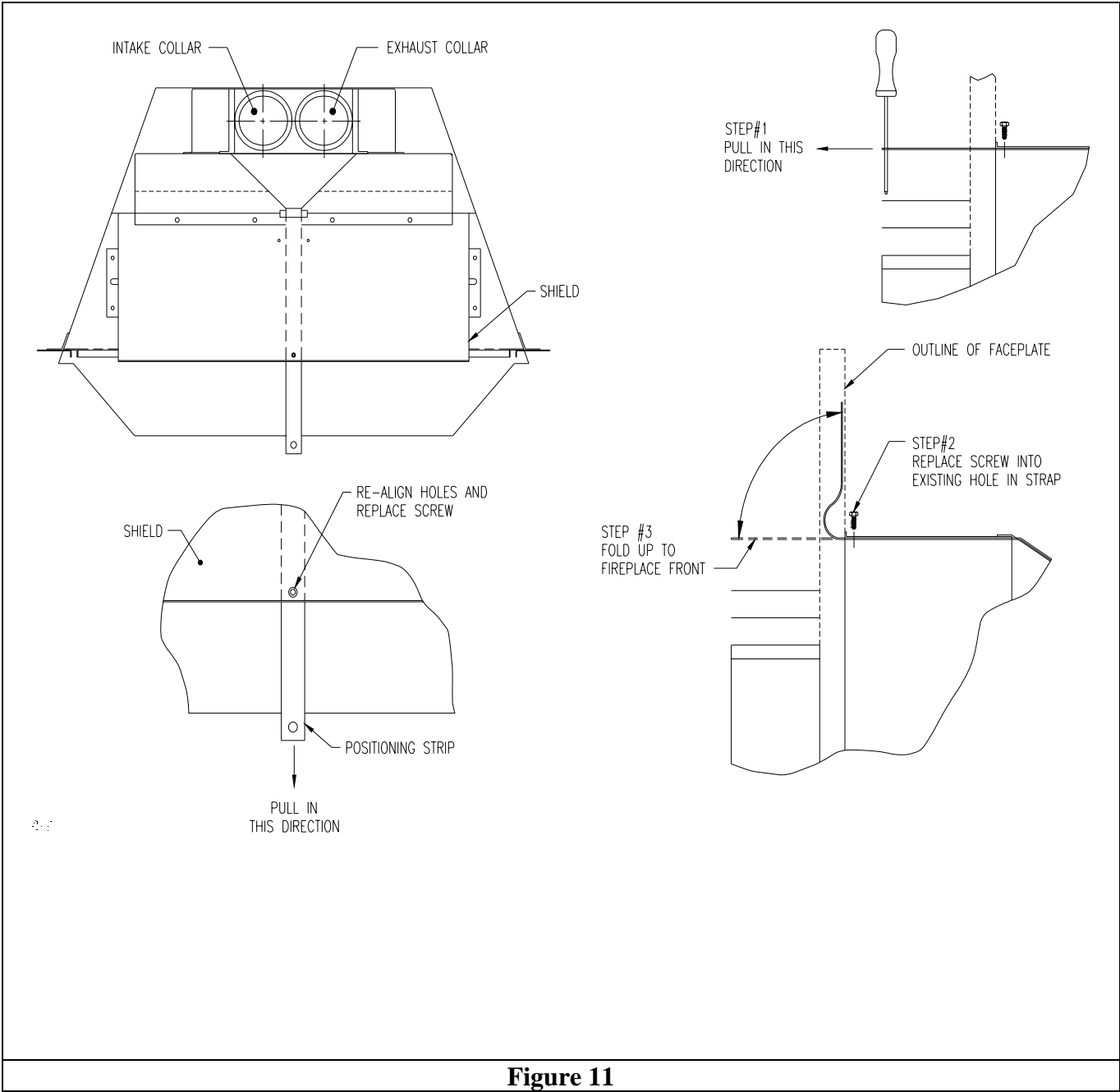
4. Liberally apply High Temperature Sealant to the outsides of the vent collars.
5. For installations that do not require the removal of the vent connector plate:
  - a. Push the insert back into the enclosure
  - b. Slide the liner onto the appropriate vent collars and secure them with three screws each and/or hose clamps.

**Note:** Make sure the previously identified exhaust liner is connected to the exhaust collar (see Figures 10 & 11).



**Figure 10**





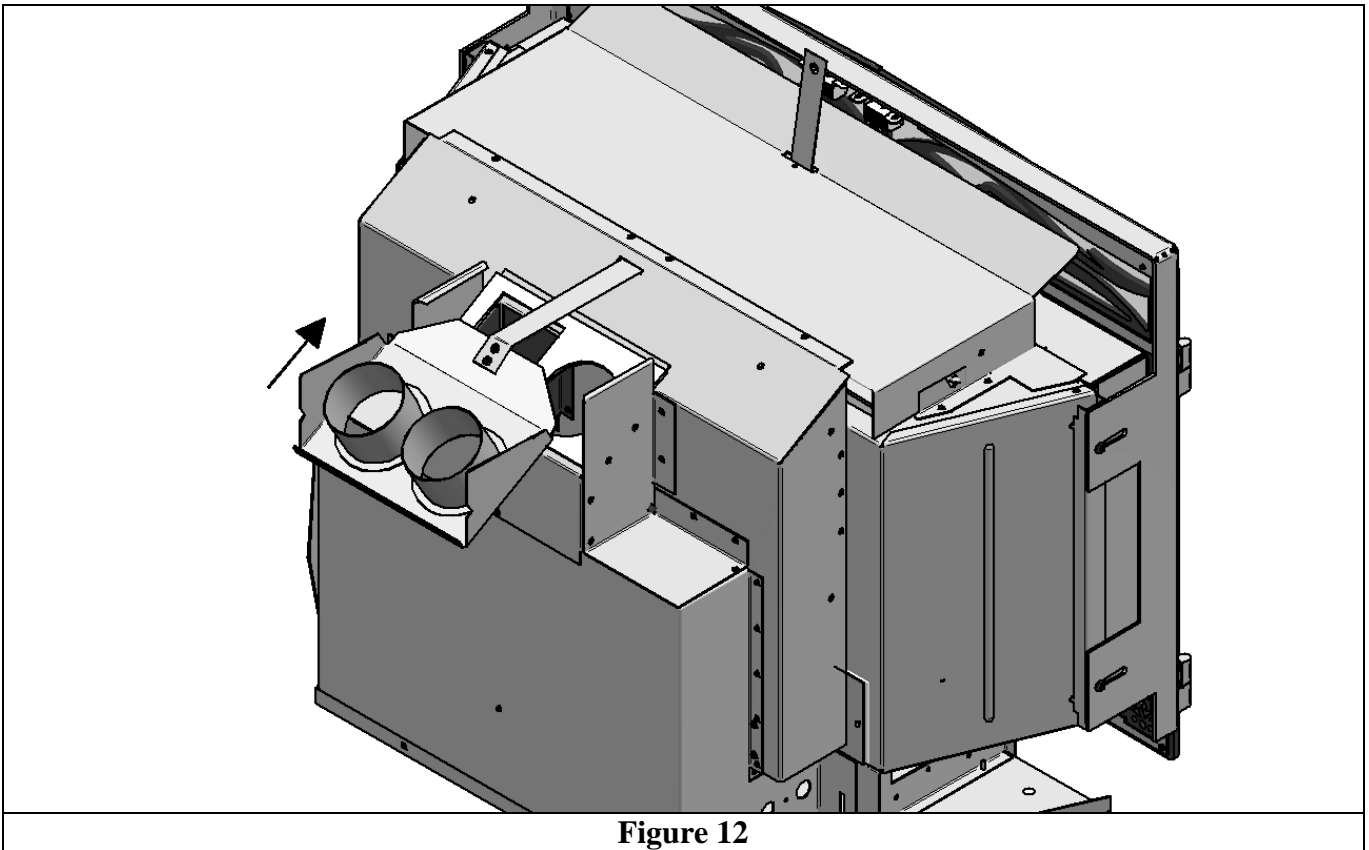
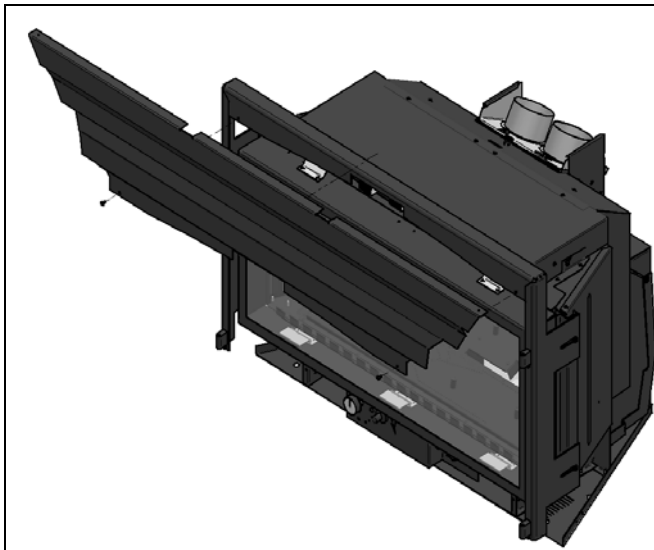


Figure 12

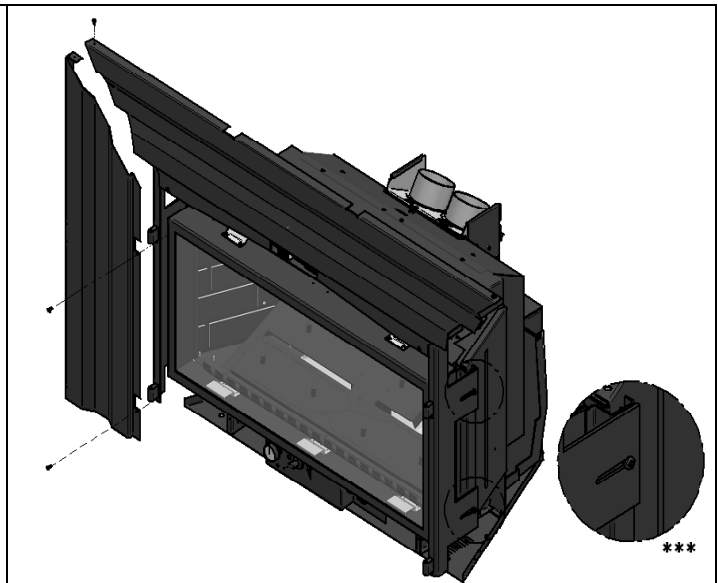
6. For installations that do require the removal of the vent connector plate:
  - a. Detach the vent connector plate by removing the screw securing the positioning strip to the top of the air jacket (Figure 11) and slide the vent connector plate off to the rear (Figure 12).
  - b. Liberally apply High-temperature Sealant to the outsides of the vent collars.
  - c. Attach the vent connector plate to the appropriate vent liners and secure with three screws each and/or hose clamps. The vent connector plate should be located 16"-20" (406-508mm) above the hearth.
  - d. Push the insert back into the enclosure, feeding the positioning strap through the slot at the top rear of the air jacket. Ensure that the strap passes freely under the air jacket and that it doesn't get caught in parts protruding from the firebox top. Continue to push the insert back as the strap is fed through until the hole on the strap lines up with the corresponding hole on the air jacket. A screwdriver can be used, if required, to help pull the strap forward. Secure the strap in position by replacing and tightening the screw in the top of the air jacket (Figure 11).
  - e. Bend the forward end of the strap back and up against the fireplace front so that the faceplate can be installed (Figure 11).

### 3.3.5 Faceplate Installation

1. Remove the faceplate panels from the packaging and assemble according to the following instructions:
2. Using two (2) screws, fix the upper faceplate panel onto the faceplate frame pre-mounted on the insert (Figure 13).
3. Using two(2) screws (per panel), install the side panels onto the frame in a way where the side panels overlaps the upper panel and the bent strip of the side panels slides under the upper panel(Figure 14).
4. Secure left and right end of the upper panel to the side panels using one (1) screw each side (Figure 14).

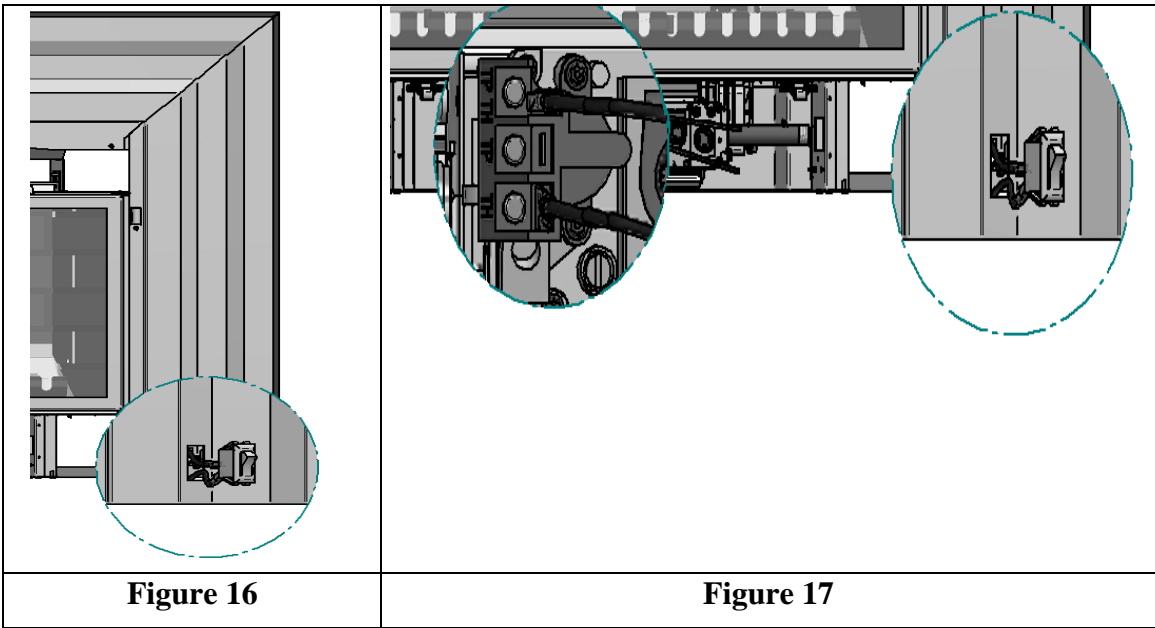
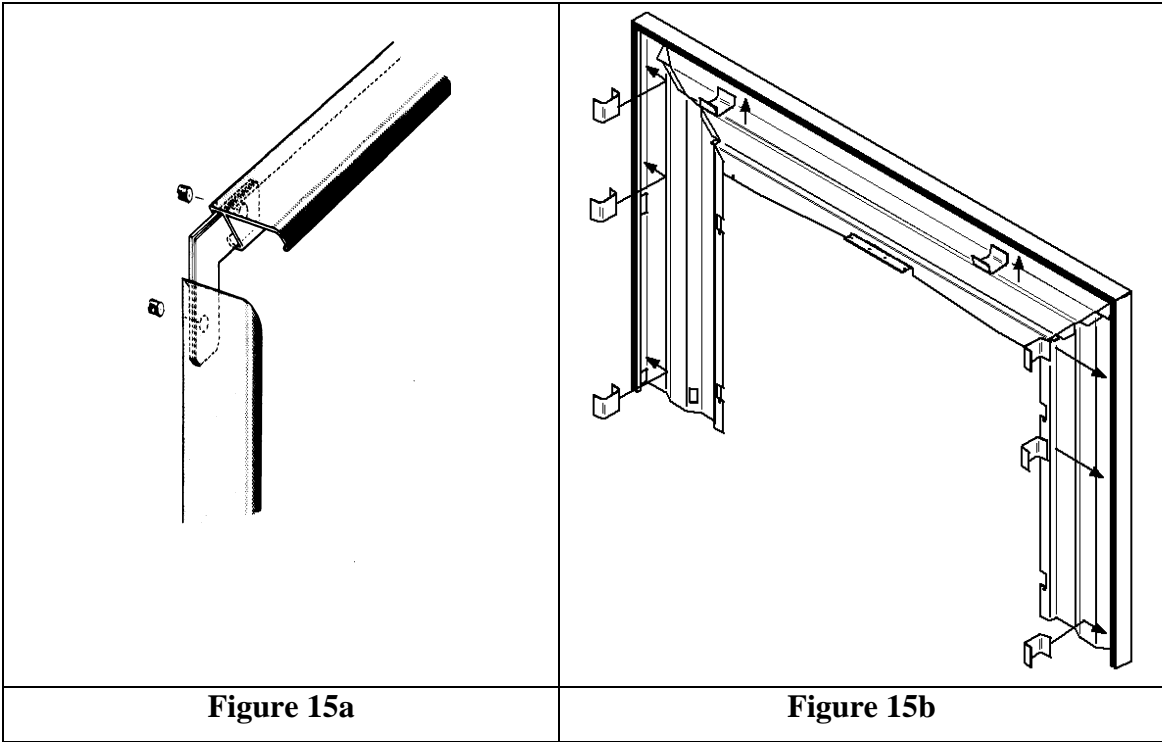


**Figure 13**



**Figure 14**

5. Attach the left and right brass trim sides to the top trim with the corner brackets supplied (Figure 15a).
6. Slip the assembled trim over the faceplate and push the faceplate trim clips between the trim and the faceplate (two on the top edge and three down each side) (Figure 15b).
7. Push the burner switch through the hole in the front right hand faceplate and connect the switch to the gas valve (Figure 16 & 17).
8. \*\*\*The faceplate frame is attached to the unit with four (4) screws, when loosen the frame can be move front to rear for faceplate adjustment (Figure 14).
9. Push the insert into the fireplace opening until the faceplate trim is sealed against the fireplace facing.



### 3.3.6 Fire box components installation

#### 3.3.6.1 Installing logs

**Step 1:** Place the rear log on the pins located on the burner tray.



**Step 2:** Place the front right log on the pins located on the burner tray.



## Installing Logs - continued

**Step 3:** Place the left front log on the pins located on the burner tray.



**Step 4:** Place the top “Y” log on the rear and front right log using the fixation pins located on the back and front right logs.

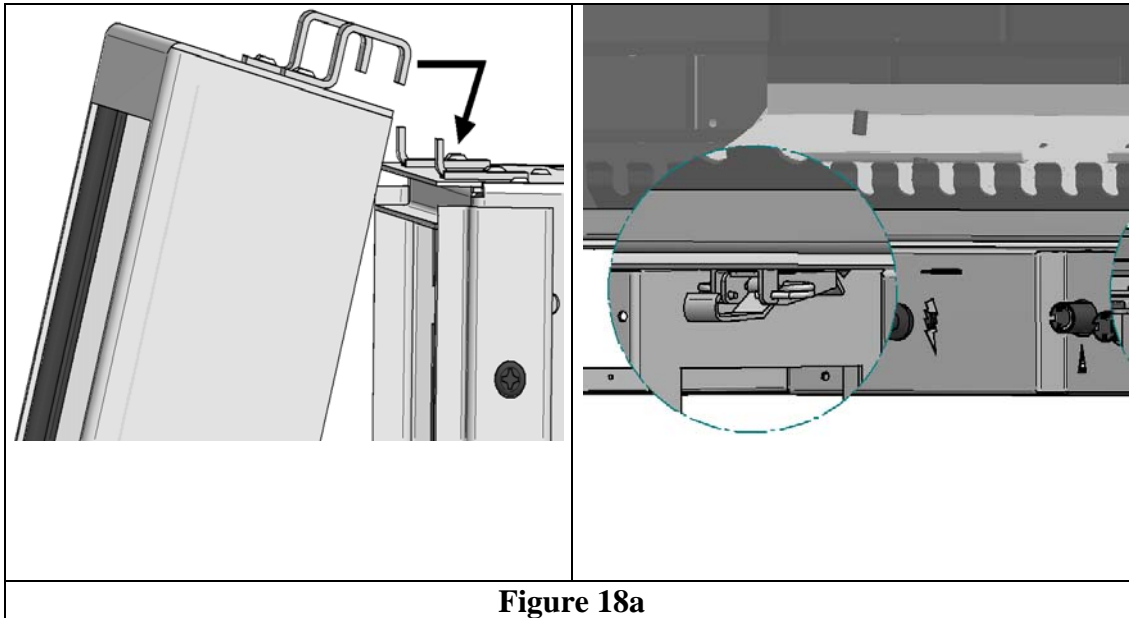




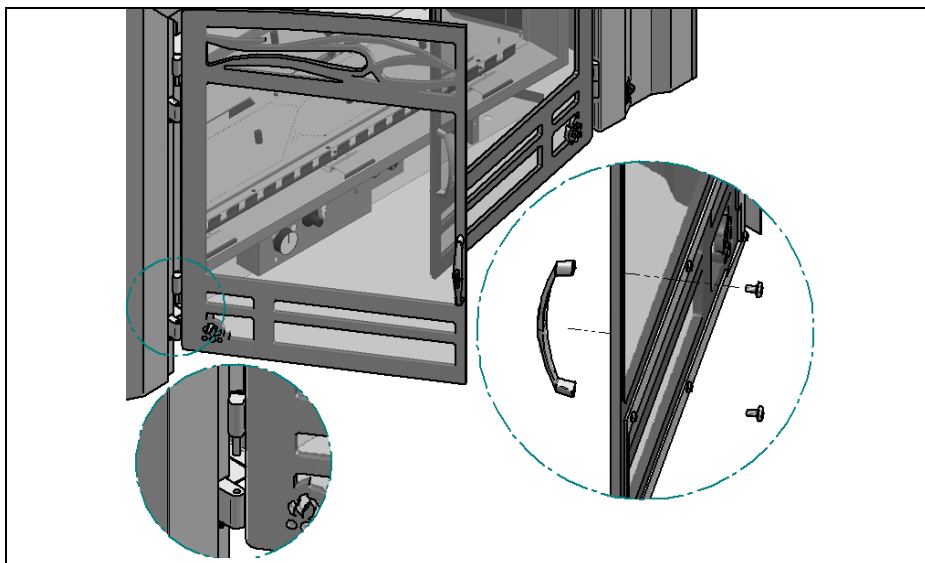
### 3.3.6.2 Installing or Removing the Glass Door

Align and insert the two(2) hooks welded on the top front of the firebox into the hinges welded on the door frame then attached the two (2) hook clamps located on the front underside of the firebox to the bottom door hinges. Removal is reverse order.

**Warning:** Do not operate the appliance with the glass front removed, cracked or broken. Replacement of the glass should be done by a licensed qualified service person.



### 3.3.6.3 Decorative doors installation



### 3.3.7 Initial firing

At the time of the first burn, the appliance may emit an odor, accompanied by smoke. This is perfectly normal. As the metal heats to the critical point (about 375 degrees F), part of the paint components turns to light gray smoke as the dormant silicone resin activates and begins to bond with the metal. After the “burn-off” is complete, there will be no more smoke or odor. Although the smoke/odor is not toxic, it is annoying and it displaces oxygen. After the fireplace has been burned about three times (for at least one hour), the entire surface will have cured. If the process is not complete, it will continue to give off some odor. It is important to ventilate the house during these initial burns. We advise removing young children, elderly persons and anyone suffering from breathing disorders (or are sensitive to oxygen imbalances) from the area while this process is occurring.

**NOTE:** It is normal for the appliance to expand and contract while it heats up or cools down whether this is from a cold start or a steady-state condition where the fan has come on or off. Under these circumstances it is possible that the expansion/contraction of the metal parts may produce a ticking sound. Occasionally, after a cold start, vapor may condense and fog the glass, and the flames may be partially blue. After a few minutes the moisture will disappear and the flames will become yellow. Visually check the maximum flame height after warm-up (Figure 19).



Figure 19



### 3.3.7.1 Manifold pressure regulator adjustment

The manifold pressure regulator controls gas input and flame height, and is pre-adjusted at the factory. No further adjustment is required. Manifold pressure can be verified only (Figure 3).

### 3.3.7.2 Pilot adjustment

For proper operation, the pilot and main burner flames must be steady and not lifting off or floating. The top 3/8" – 1/2" (10-13mm) of the thermopile should be engulfed by the pilot flame. The pilot flame adjustment should be performed by a qualified service person only. To adjust the pilot flame, turn the pilot adjustment screw counter-clockwise to increase and clockwise to decrease the flame. Ensure that the pilot flame completely engulfs the thermopile (Figure 20).

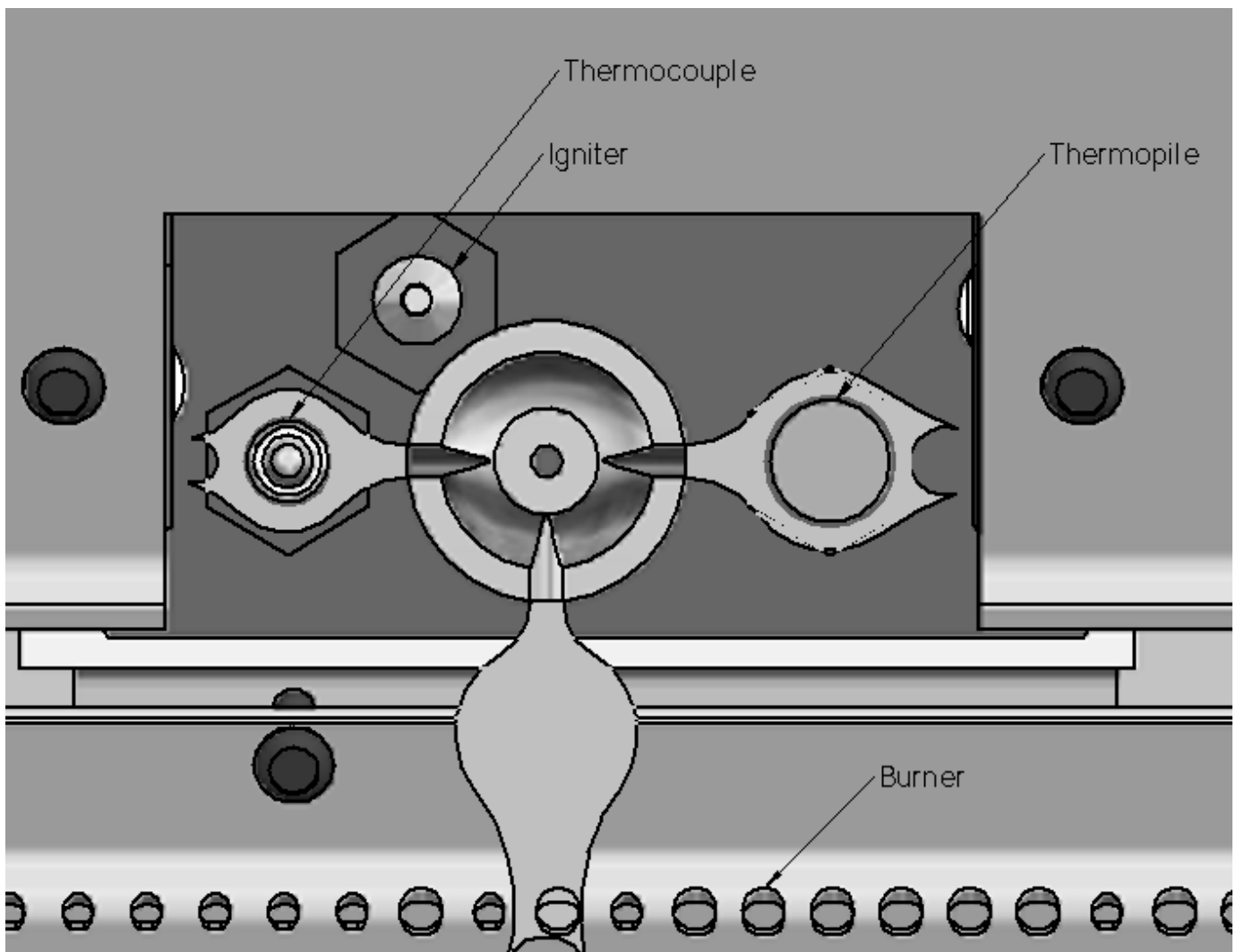


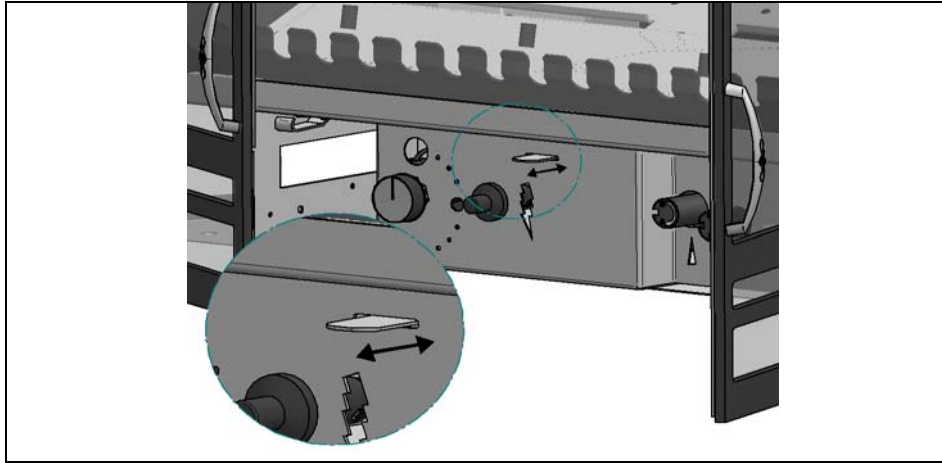
Figure 20

### 3.3.7.3 Primary air adjustment

***Too little aeration may result in black carbon forming and dropping into the firebox.***

For most installations use air adjustment according to table 1. However in a very few instances performance may be improved by sliding the adjustment lever (see figure below).

To gain access to the air shutter lever open the decorative front doors, the lever passes through the control panel cover. Pushing the lever to the rear increases aeration which will cause the flames to appear more transparent and blue making the ceramic logs glow more. Sliding the lever to the front decreases aeration and will cause the flames to appear more yellow or orange making the ceramic logs glow less. Evaluate the aeration only after the unit has warmed up approximately 45 minutes.



**Figure 21**

### 3.3.7.4 Damper Adjustment

The insert has an internal damper to compensate for taller chimney installations. The damper is set at the factory for installations with up to 13' of vent (Figure 22).

To adjust damper:

1. Open the decorative doors
2. Loosen, but do not remove, actuator lock screw.
3. Pull or push the actuator to the required setting for your vent length (see Table 3).
4. Tighten actuator lock screw and close the decorative doors.

CHIMNEY HEIGHT	ACTUATOR POSITION	FLUE RESTRICTION
11'	A	↓ ↓ ↓ MORE
18'	C	
24'	E	
26'	G	
28'	I	
30'	K	MORE

TABLE 3

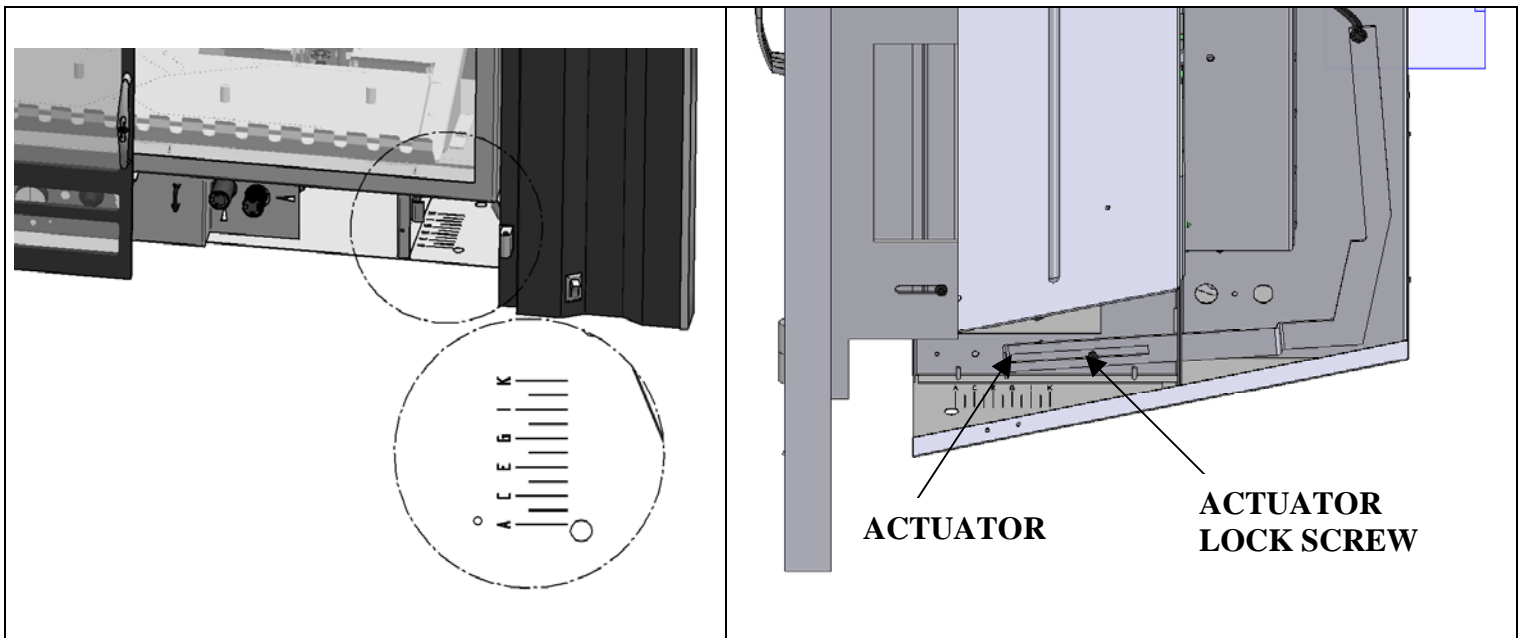


Figure 22

### 3.3.7.5 Altitude adjustment

All valves have been preset and certified for installation at elevations from 0 - 4500 feet (0-1372m) above sea level. When installing this insert at higher elevations, it is necessary to decrease the input rating, by changing the existing burner orifice to a smaller size, consult local codes. Input should be reduced 4% for each additional 1000 feet above sea level. Use Tables 5A & 5B or check with the local gas authorities for proper orifice size identification. For the USA, derate the heater from sea level according to the gas installation code.

#### Altitude adjustment by changing the burner orifice (Natural Gas)

ALTITUDE up to (ft)	REDUCTION (%)	ORIFICE SIZE (DMS)	TARGET INPUT (BTU/hr)	MANIFOLD PRESSURE (in.wc)
4500	-	36	35,000	3.5
5500	4	37	33,600	3.5
6500	8	38	32,200	3.5
7500	12	39	30,800	3.5
8500	16	40	29,400	3.5
9500	20	40	28,000	3.5
10500	24	41	26,600	3.5
11500	28	42	25,200	3.5

**TABLE 5A  
(Propane / LP Gas)**

ALTITUDE up to (ft)	REDUCTION (%)	ORIFICE SIZE (DMS)	TARGET UNPUT (BTU/hr)	MANIFOLD PRESSURE (in. wc)
4500	-	50	35,000	10
5500	4	51	33,600	10
6500	8	51	32,200	10
7500	12	52	30,800	10
8500	16	52	29,400	10
9500	20	53	28,000	10
10500	24	53	26,600	10
11500	28	54	25,200	10

**TABLE 5B**

### 3.3.8 Burner removal

Burner removal is very simple, first ensure the unit is turned off and cooled to room temperature. Open the door remove the logs, remove the 2 burner mounting screws (one on the left and one on the right) and lift the burner out of the unit. When re-installing the burner make sure that the air shutter covering the burner is adjusted to the type of gas used.

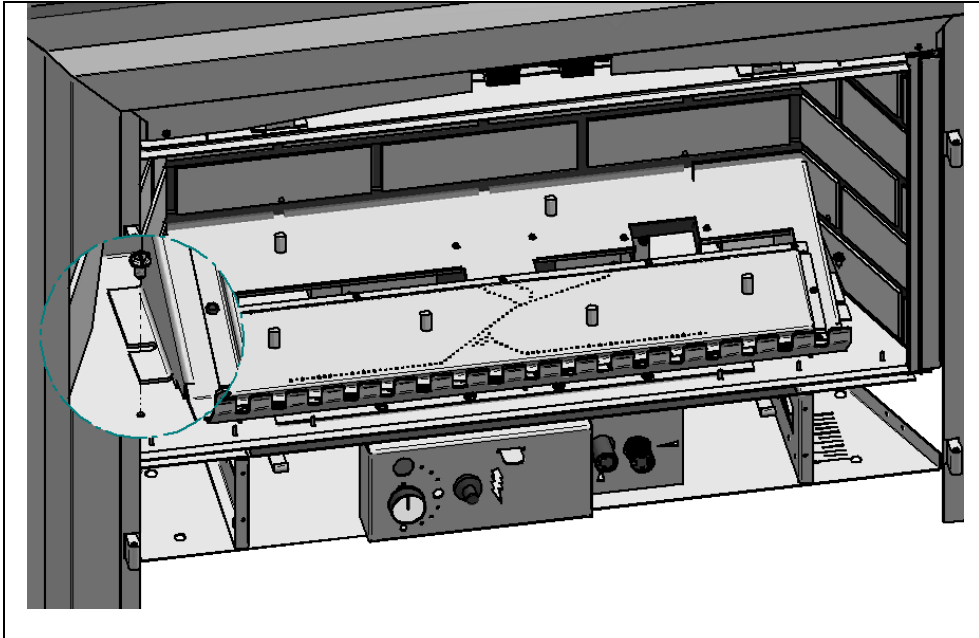


Figure 23

### 3.3.9 FIELD CONVERSIONS

Turn off the gas supply to the unit and allow the heater to cool for up to 30 minutes before servicing.

The following procedure is to be performed by qualified service personnel ONLY.

Local building codes and installation codes must be adhered to.

1. Open the decorative doors
2. Remove the door carefully and set it in a safe place away from traffic areas.
3. Lift the top log off the location pins first. Then lift the two front logs and the rear log up off of the location pins on the burner tray. Store in a safe place.
4. Remove the two Phillips head screws at each end of the burner tray. Then remove the two Phillips head screws in the centre of the burner by accessing them through the air slots in the burner tray.
5. Remove the burner tray assembly by lifting it up and towards you, then out of the firebox.
6. Remove the pilot hood by pulling it straight up and then unscrew the pilot orifice using an Allen key. Screw in the new orifice and replace the pilot hood by pushing it down until it snaps into the spring clip. Note: the pilot hood will only go in one way.
7. Remove the burner orifice by unscrewing it from the 90-degree elbow and passing it through the air shutter plate.
8. Remove the valve control panel.
9. Remove the two valve extension knobs to access the “Hi-LOW” regulator.
10. Using the included 820 NOVA instructions (steps one to four), remove and replace the old regulator with the new regulator, and install the valve conversion label.
11. Re-install the burner assembly and log set.
12. Set air shutter as per table 1 and instructions in 3.3.6.3.
13. Reinstall components in reverse order.
14. Fill out the conversion label and install it near the “ CAUTION: HOT WHILE IN OPERATION “ label.
15. Follow steps five to seven on the 820 NOVA instructions

## **4.0 MAINTENANCE**

### **4.1 Maintenance safety**

**Turn off the gas to the main burner and allow the heater to cool for up to 30 minutes before servicing.**

Service and repair should be done by a qualified service person. The appliance should be inspected before use and at least annually by a professional service technician. More frequent cleaning may be required due to excessive lint from carpeting, bedding material, etc. It is important that the access door compartment, burner, and circulating air passageways be kept clean to provide for adequate combustion and ventilation airflow. Do not substitute materials or use components other than factory supplied.

### **4.2 Recommended service**

1. Examine the venting system periodically.
2. Visually check the burner and pilot flames occasionally. Visually inspect height and color of flames.
3. Clean the glass as needed. See section 4.3 for instructions on glass cleaning.
4. Have the appliance inspected annually by a professional service technician.
5. Clean the appliance regularly.

**NOTE: Safety screens removed for service must be replaced prior to operating the heater.**

Annual service: An annual service call should take between 1 – 2 hours. Start by disassembling the unit; take off the glass and remove all the logs, embers, burner, and fan. A small toothbrush is a handy tool for cleaning the fan. Loosen all the debris on the fan blades and vacuum it off. Vacuum the whole firebox and all the air passages. Clean the burner, pilot orifice, main orifice, logs, etc. After everything is clean, check all the connections and the chassis ground and reassemble. Fire up the unit and check the electrical readings of the thermopile/thermocouple. Clean the glass. Check the gas pressure. Check the draft (the venting system should also be checked).

### **4.3 Glass cleaning**

The inside of the glass may require periodic cleaning to remove deposits left from impurities in the gas and combustion air. For best results, use a ceramic glass cleaner or polish. A suitable cleaner is available from your dealer. Avoid the use of ammonia based cleaners such as Windex<sup>®</sup>. Do not clean while hot. Do not use abrasive cleaners. Make sure you clean off the white film on the fireplace glass as soon as possible – otherwise the glass may deteriorate.

## 4.4 Cleaning of gold plated surfaces

Take special care and **DO NOT** use chemical or abrasive cleaners. Wipe only with a soft damp cotton cloth to maintain original brilliance. Do not clean plated surfaces when they are still hot.

**CAUTION:** Vigorous wiping may damage the gold finish.

## 4.5 Burner & pilot cleaning

Periodic cleaning is necessary for proper operation.

Refer to section 4.8, remove the burner, and check that the burner orifice is clean.

Visually inspect the pilot. Brush or blow away any dust, lint, or foreign debris. If the pilot orifice is plugged, disassembly may be required to remove any foreign material from the orifice or tubing. When the appliance is back in service, check the pilot flame pattern with the figures in Section 3.3.6. For re-lighting, refer to the lighting instructions in Section 2.2.

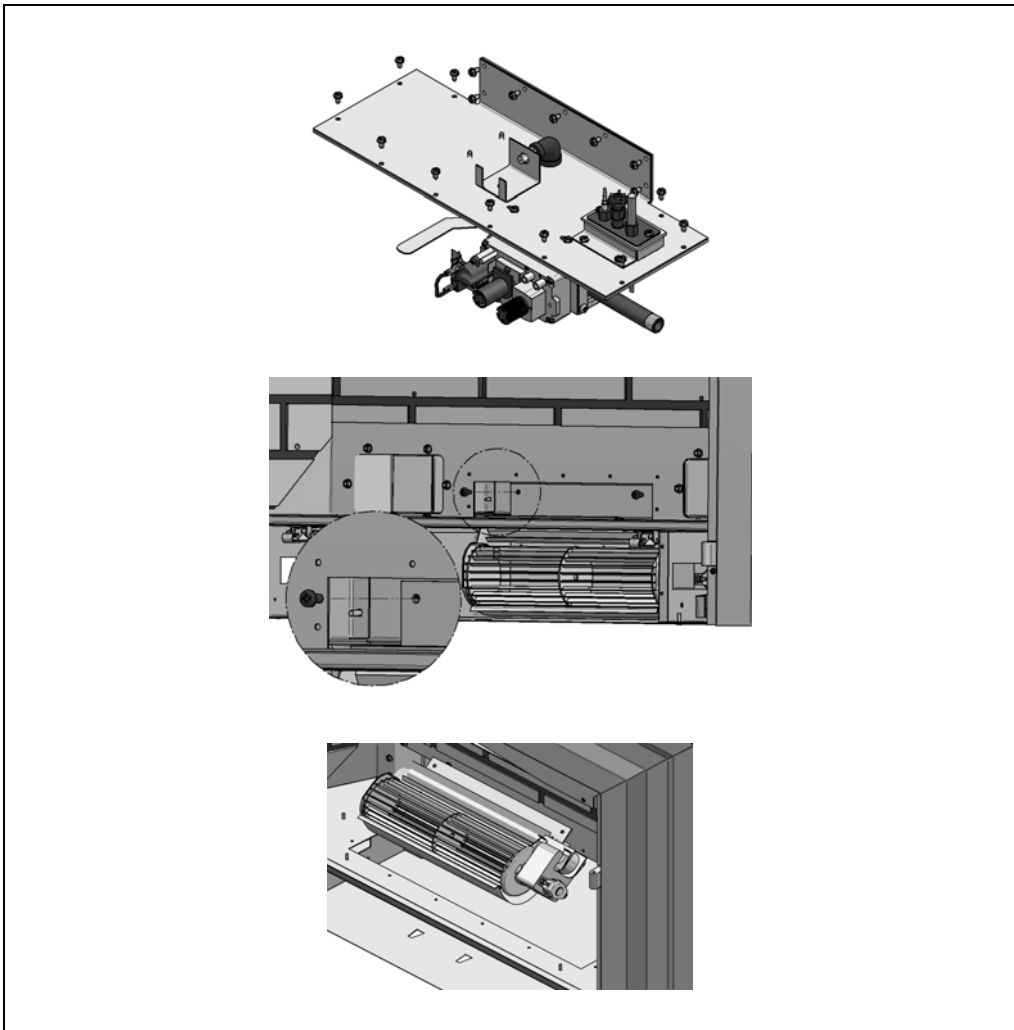
## 4.6 Fan replacement & electrical schematic

“Caution: Label all wires prior to disconnection when servicing controls. Wiring errors can cause improper and dangerous operation. Verify proper operation after servicing.

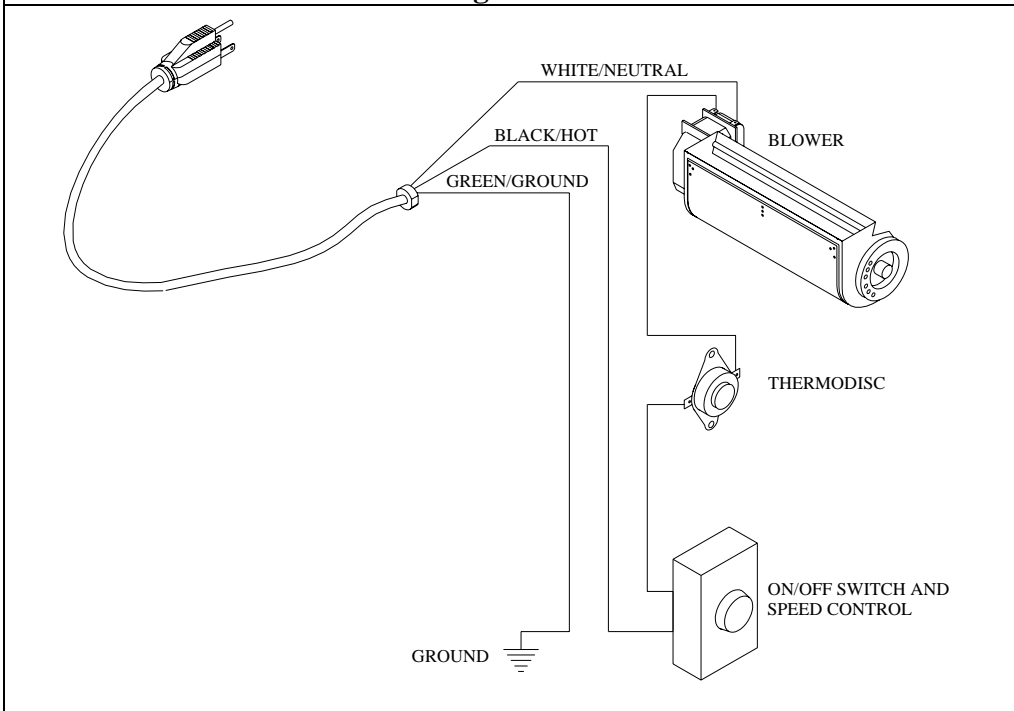
1. Cut the gas supply to the valve assembly then disconnect the supply line at the valve.
2. Open the decorative doors and remove the glass door and control panel (Figure 18a).
3. Remove the burner (Figure 23).
4. Remove the screws that secures the valve assembly in place, lift the assembly and pull it out of the firebox to access the fan assembly (Figure 24).
5. Finally remove the two (2) screws that secures the fan assembly and proceed with the maintenance or replacement.

**NOTE :** If the valve assembly gasket is damage during the removal process, it has to be replaced by a new one.





**Figure 24**



**Figure 25**

## 5.0 TROUBLE SHOOTING

SYMPTOM	POSSIBLE CAUSE	CORRECTIVE ACTION
I. Pilot will not light after repeated triggering of the piezo ignition button	<b>A. No spark at electrode (weak or not heat source for pilot ignition)</b>	
	<ol style="list-style-type: none"> <li>1. Improper ignition</li> <li>2. Poor connections at igniter and ignition electrode</li> <li>3. Broken ceramic cover on ignition electrode</li> <li>4. Defective piezo igniter</li> </ol>	<ol style="list-style-type: none"> <li>1. Align the electrode with 1/8" (3mm) gap to pilot hood</li> <li>2. Reconnect if loose</li> <li>3. Replace pilot assembly</li> <li>4. Replace piezo igniter</li> </ol>
	<b>B. No gas or low gas pressure</b>	
	<ol style="list-style-type: none"> <li>1. Gas line shut off(s) may not be turned on</li> <li>2. No gas supply (LPG)</li> <li>3. Air in gas lines</li> <li>4. Gas lines may not be connected</li> <li>5. Low pressure may be caused by bent line</li> <li>6. Valve control knob not fully depressed in "PILOT" position</li> </ol>	<ol style="list-style-type: none"> <li>1. Turn of shut-off valves</li> <li>2. Check propane tank; you may be out of fuel</li> <li>3. Purge gas lines</li> <li>4. Connect all gas lines</li> <li>5. Check for a kinked line</li> <li>6. Fully depress control knob</li> </ol>
II. Pilot will not stay lit after following the lighting instructions	<b>A. Thermocouple / Valve</b>	
	<ol style="list-style-type: none"> <li>1. Weak or improperly located pilot flame</li> <li>2. Defective thermocouple</li> <li>3. Thermocouple not installed properly</li> <li>4. Open wire connection in pilot circuit</li> </ol>	<ol style="list-style-type: none"> <li>1. Adjust and clean pilot. The flame must impinge on or engulf the thermocouple, as shown on page 31.</li> <li>2. Have the thermostat contacts open and pilot lit with the knob turned to the "Pilot" position. Reading should be a minimum of 18 mV for a new thermocouple, if the reading is less than 18mV replace the thermocouple.</li> <li>3. Make sure all wire connections at the gas valve terminals are tight and the thermocouple is fully inserted into the mounting bracket</li> <li>4. Check wire continuity and connections in the pilot circuit</li> </ol>

III. Main burner will not light	<b>A. Valve / Switches</b>	
	<ol style="list-style-type: none"> <li>1. Valve control off</li> <li>2. Blockage at the burner (line, orifice, or ports)</li> <li>3. Defective wall switch or thermostat</li> <li>4. Defective wiring or connections</li> <li>5. Excessive length of thermostat wire from valve to wall switch or thermostat</li> <li>6. Wall switch or thermostat incorrectly wired</li> <li>7. Defective Valve</li> <li>8. Thermopile may not be generating sufficient voltage (460 mV)</li> <li>9. Wall switch, thermostat, or wires are defective</li> <li>10. Defective spill switch (B-Vent)</li> </ol>	<ol style="list-style-type: none"> <li>1. Turn to "ON" position</li> <li>2. Check and clean</li> <li>3. Conduct a continuity test or jumper wire test and replace if defective</li> <li>4. Conduct a test with a jumper wire and repair as required</li> <li>5. Reduce wire length to less than 100 feet or increase wire size</li> <li>6. Wire correctly</li> <li>7. Turn valve and "ON/OFF" switch to the "ON" position. Check with millivolt meter at terminals TP-TH &amp; TH. Millivolt meter should read greater than 460 millivolts. If the reading is OK and the burner does not come on, replace the gas valve</li> <li>8. Recheck using the millivolt meter. The pilot flame may not be high enough for the flame to properly engulf the thermopile. If so, adjust and reset. If voltage is still insufficient, replace thermopile</li> <li>9. Follow previous corrective action, check switch and wiring. Replace where defective</li> <li>10. Check continuity and replace if defective</li> </ol>
<b>IV. Soot deposits on glass</b>	<ol style="list-style-type: none"> <li>1. Flame impingement on logs</li> <li>2. Improper primary air setting Foreign material impeding burner</li> <li>3. Air inlet blocked or restricted</li> <li>4. Vent system is restricted or inadequate</li> </ol>	<ol style="list-style-type: none"> <li>1. Adjust the log set to avoid direct flame impingement. Follow log placement instructions</li> <li>2. Open aeration shutter more.</li> <li>3. Ensure that no foreign material blocks burner flame ports</li> <li>4. Clean air inlets</li> <li>5. Conduct flue spillage test (B Vent) and correct flue as required, check correct termination is used.</li> </ol>
<b>V. Flame burns blue and lifts off burner</b>	<ol style="list-style-type: none"> <li>1. Insufficient combustion air being supplied</li> </ol>	<ol style="list-style-type: none"> <li>1. Ensure that no foreign material blocks air inlets and that the burner shutter is correctly adjusted. Ensure the vent is adequate</li> </ol>
	<ol style="list-style-type: none"> <li>2. Manifold pressure set too high</li> <li>3. Vent system restricted</li> </ol>	<ol style="list-style-type: none"> <li>2. Check manifold pressure</li> <li>3. Check vent system</li> </ol>
<b>VI. Flames impinge on firebox top</b>	<ol style="list-style-type: none"> <li>1. Vent system is restricted or inadequate</li> <li>2. Manifold pressure too high</li> </ol>	<ol style="list-style-type: none"> <li>1. Correct flue as required</li> <li>2. Check manifold pressure as required</li> </ol>

## **6.0 REPLACEMENT PARTS**

When requesting service or replacement parts, refer to your dealer. The following information's will be asked for; the model name "Saturna", the type of gas used, serial number and proof of purchase. The damaged parts must be replaced by Osburn genuine parts. You can consult the spare parts list on our website at [www.osburn-mfg.com](http://www.osburn-mfg.com) or contact your Osburn dealer.

# OSBURN LIMITED LIFETIME WARRANTY

The warranty of the manufacturer extends only to the original consumer purchaser and is not transferable. This warranty covers brand new products only, which have not been altered, modified nor repaired since shipment from factory. Proof of purchase (dated bill of sale), model name and serial number must be supplied when making any warranty claim to your OSBURN dealer.

**This warranty applies to normal residential use only. Damages caused by misuse, abuse, improper installation, lack of maintenance, negligence or accident during transportation are not covered by this warranty.**

This warranty does not cover any scratch, corrosion, warping, or discoloration caused by over firing, abrasives or chemical cleaners. Any defect or damage caused by the use of unauthorized parts or others than original parts void this warranty. An authorized qualified technician must perform the installation in accordance with the instructions supplied with this product and all local and national building codes. Any service call related to an improper installation is not covered by this warranty.

The manufacturer may require that defective products be returned or that digital pictures be provided to support the claim. Returned products are to be shipped prepaid to the manufacturer for investigation. If a product is found to be defective, the manufacturer will repair or replace such defect and reasonable transportation fees will be refunded. Repair work covered by the warranty, executed at the purchaser's domicile by an authorized qualified technician requires the prior approval of the manufacturer. Labour cost and repair work to the account of the manufacturer are based on predetermined rate schedule and must not exceed the wholesale price of the replacement part. All labour and freight costs covered by this warranty are limited according to the table below.

The manufacturer at its discretion may decide to repair or replace any part or unit after inspection and investigation of the defect. The manufacturer may, at its discretion, fully discharge all obligations with respect to this warranty by refunding the wholesale price of any warranted but defective parts. The manufacturer shall in no event be responsible for any special, indirect, consequential damages of any nature, which are in excess of the original purchase price of the product.

DESCRIPTION	WARRANTY APPLICATION	
	PARTS	LABOUR
Combustion chamber (welds only), heat exchanger, and castings.	Lifetime	5 years
Plating (defective manufacture) – subject to limitations above	Lifetime	n/a
Burner	5 years	3 years
Stainless steel baffle and parts	5 years	3 years
Carbon steel baffle and parts	2 years	1 year
Ceramic logs, masonry-like panels, and ceramic glass (thermal breakage only*)	2 years	n/a
Gas valve, pilot assembly & related parts, blowers, switches, rheostat, and other controls.	1 year	1 year
Paint (peeling) and gaskets	1 year	n/a

*\*Pictures required*

Shall your unit or a components be defective, contact immediately your OSBURN dealer. Prior to your call make sure you have the following information necessary to your warranty claim treatment:

- **Your name, address and telephone number;**
- **Bill of sale and dealer's name;**
- **Serial number and model name as indicated on the nameplate fixed to the back of your unit;**
- **Nature of the defect and any relevant information.**

**Before shipping your unit or defective component to our plant, you must obtain from your OSBURN dealer an Authorization Number. Any merchandise shipped to our plant without authorization will be refused automatically and returned to sender.**